

# Transient Voltage Suppression Diodes: TPSMAJ Series

## SMD Type 400 W



### ■ Features

1. For surface mounted applications
2. RoHS compliant and halogen-free
3. Reliable low cost construction utilizing molded plastic technique
4. Glass passivated chip junction
5. Both bi-directional and uni-directional devices are available
6. Low leakage
7. Fast response time
8. Excellent clamping capability
9. 400W peak pulse power capability with a 10/1000  $\mu$ s waveform, repetitive rate (duty cycle): 0.01%
10. High reliability application and automotive grade AEC Q101 qualified



### ■ Recommended Applications

1. Telecommunication
2. Computer
3. Industrial device
4. Consumer electronic device
5. Automotive

### ■ Mechanical Data

1. Case: DO-214AC (SMA), molded plastic meets UL flammability rating 94V-0
2. Terminal: Matte Tin-plated leads, solderable per MIL-STD-750, method 2026.
3. Polarity: The band denotes cathode (Note: no polarity indicator for bi-directional devices)

### ■ Part Number Code

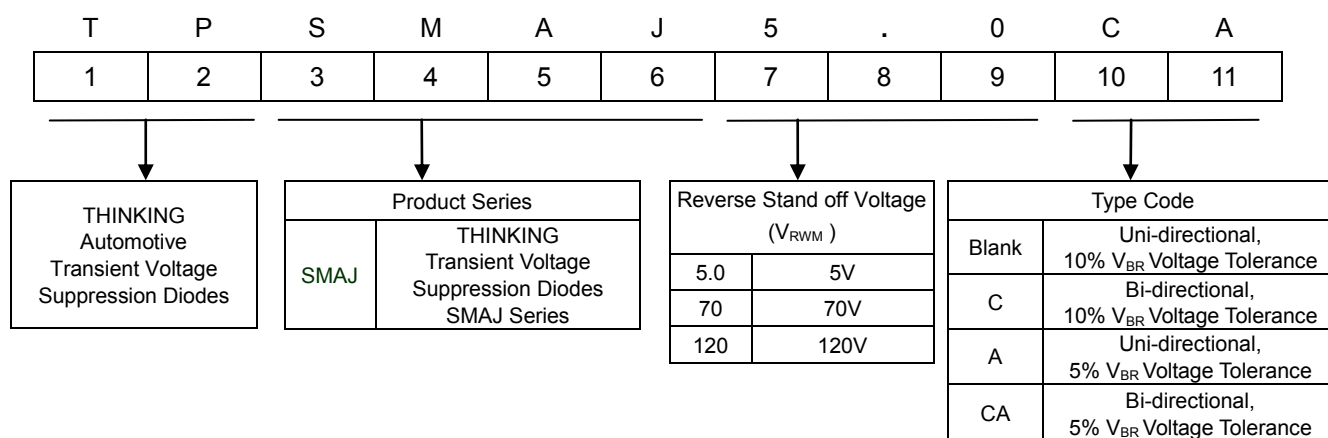

# Transient Voltage Suppression Diodes: TPSMAJ Series

## SMD Type 400 W



### Structures and Dimensions

SMA/ DO-214AC

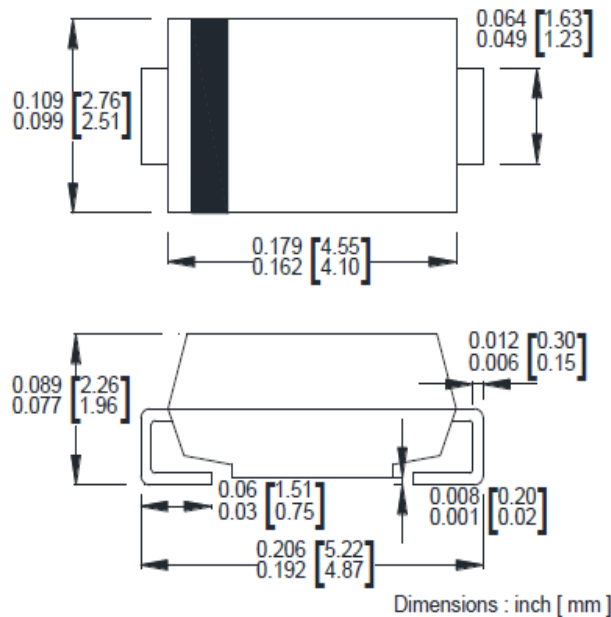

### Maximum Rating ( $T_A=25^{\circ}\text{C}$ unless otherwise noted)

Parameter	Symbol	Value	Unit
Peak pulse power dissipation at $T_A=25^{\circ}\text{C}$ by 10/1000 $\mu\text{s}$ waveform (Note1)	$P_{PPM}$	400	W
Peak pulse current of on 10/1000 $\mu\text{s}$ waveform.(Note1)	$I_{PPM}$	See Table	A
Peak forward surge current, 8.3ms single half sine wave on rated load (Note 2)	$I_{FSM}$	40	A
Power dissipation on infinite heatsink at $T_L=75^{\circ}\text{C}$	$P_D$	1.0	W
Operating junction and storage temperature range	$T_J, T_{STG}$	-55~+150	$^{\circ}\text{C}$

Note: 1. Please refer to Fig. 5 for non-repetitive current pulse, and Fig. 1 for derated above  $T_A = 25^{\circ}\text{C}$

2. 8.3ms single half sine-wave, or square wave that has a maximum of 4 pulses per minute.

# Transient Voltage Suppression Diodes: TPSMAJ Series

## SMD Type 400 W



### ■ Electrical Characteristics (T<sub>A</sub>=25°C unless otherwise noted)

Part No. (Uni)	Part No. (Bi)	Reverse Stand off Voltage	Breakage Voltage VBR @ IT		Test Current	Maximum Clamping Voltage VC @ Ipp	Maximum Peak Pulse Current	Maximum Reverse Leakage IR @VRWM	Marking Code	
		VRWM ( V )	Min( V )	Max( V )	IT( mA )	VC( V )	Ipp(A)	IR(μA)	UNI	BI
TPSMAJ10A	TPSMAJ10CA	10	11.1	12.3	1	17	23.53	5	AXA	WXA
TPSMAJ11A	TPSMAJ11CA	11	12.2	13.5	1	18.2	22.98	1	AZA	WZA
TPSMAJ12A	TPSMAJ12CA	12	13.3	14.7	1	19.9	20.10	1	BEA	XEA
TPSMAJ13A	TPSMAJ13CA	13	14.4	15.9	1	21.5	18.60	1	BGA	XGA
TPSMAJ14A	TPSMAJ14CA	14	15.6	17.2	1	23.2	17.24	1	BKA	XKA
TPSMAJ15A	TPSMAJ15CA	15	16.7	18.5	1	24.4	16.39	1	BMA	XMA
TPSMAJ16A	TPSMAJ16CA	16	17.8	19.7	1	26	15.38	1	BPA	XPA
TPSMAJ17A	TPSMAJ17CA	17	18.9	20.9	1	27.6	14.49	1	BRA	XRA
TPSMAJ18A	TPSMAJ18CA	18	20	22.1	1	29.2	13.70	1	BTA	XTA
TPSMAJ19A	TPSMAJ19CA	19	21.1	23.3	1	30.8	13.00	1	BBA	XBA
TPSMAJ20A	TPSMAJ20CA	20	22.2	24.5	1	32.4	12.35	1	BVA	XVA
TPSMAJ22A	TPSMAJ22CA	22	24.4	26.9	1	35.5	11.27	1	BXA	XXA
TPSMAJ24A	TPSMAJ24CA	24	26.7	29.5	1	38.9	10.28	1	BZA	XZA
TPSMAJ26A	TPSMAJ26CA	26	28.9	31.9	1	42.1	9.50	1	CEA	YEA
TPSMAJ28A	TPSMAJ28CA	28	31.1	34.4	1	45.4	8.81	1	CGA	YGA
TPSMAJ30A	TPSMAJ30CA	30	33.3	36.8	1	48.4	8.26	1	CKA	YKA
TPSMAJ33A	TPSMAJ33CA	33	36.7	40.6	1	53.3	7.50	1	CMA	YMA
TPSMAJ36A	TPSMAJ36CA	36	40	44.2	1	58.1	6.88	1	CPA	YPA
TPSMAJ40A	TPSMAJ40CA	40	44.4	49.1	1	64.5	6.20	1	CRA	YRA
TPSMAJ43A	TPSMAJ43CA	43	47.8	52.8	1	69.4	5.76	1	CTA	YTA
TPSMAJ45A	TPSMAJ45CA	45	50	55.3	1	72.7	5.50	1	CVA	YVA
TPSMAJ48A	TPSMAJ48CA	48	53.3	58.9	1	77.4	5.17	1	CXA	YXA
TPSMAJ51A	TPSMAJ51CA	51	56.7	62.7	1	82.4	4.85	1	CZA	YZA
TPSMAJ54A	TPSMAJ54CA	54	60	66.3	1	87.1	4.59	1	REA	ZEA
TPSMAJ58A	TPSMAJ58CA	58	64.4	71.2	1	93.6	4.27	1	RGA	ZGA
TPSMAJ60A	TPSMAJ60CA	60	66.7	73.7	1	96.8	4.13	1	RKA	ZKA
TPSMAJ64A	TPSMAJ64CA	64	71.1	78.6	1	103	3.88	1	RMA	ZMA
TPSMAJ70A	TPSMAJ70CA	70	77.8	86	1	113	3.54	1	RPA	ZPA
TPSMAJ75A	TPSMAJ75CA	75	83.3	92.1	1	121	3.31	1	RRA	ZRA
TPSMAJ78A	TPSMAJ78CA	78	86.7	95.8	1	126	3.17	1	RTA	ZTA
TPSMAJ80A	TPSMAJ80CA	80	88.8	97.6	1	129.6	3.09	1	RBA	ZBA
TPSMAJ85A	TPSMAJ85CA	85	94.4	104	1	137	2.92	1	RVA	ZVA

Note:

1. Add suffix "C" or "CA" after part number to specify Bi-directional devices.
2. For bidirectional type having V<sub>RWM</sub> of 10 volts and under, the I<sub>R</sub> limit is doubled.

# Transient Voltage Suppression Diodes: TPSMAJ Series

## SMD Type 400 W



### Rate and Characteristic Curve ( $T_A=25^\circ\text{C}$ unless otherwise noted)

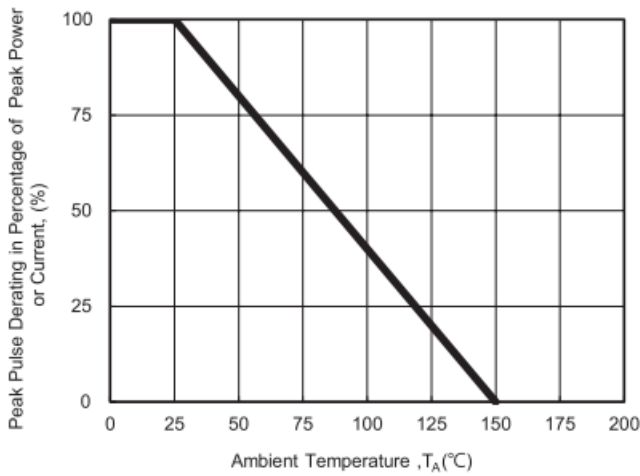

Fig. 1 - Pulse Derating Curve

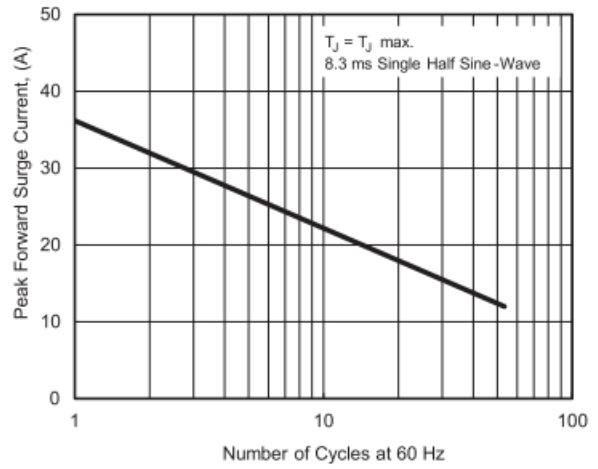

Fig. 2 - Maximum Non-Repetitive Surge Current

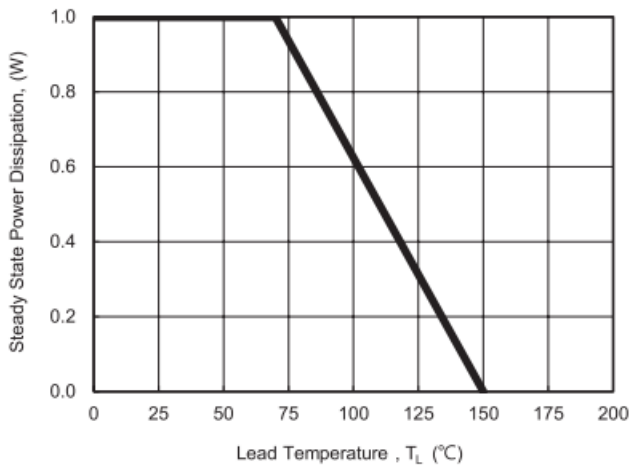

Fig. 3 - Steady State Power Derating Curve

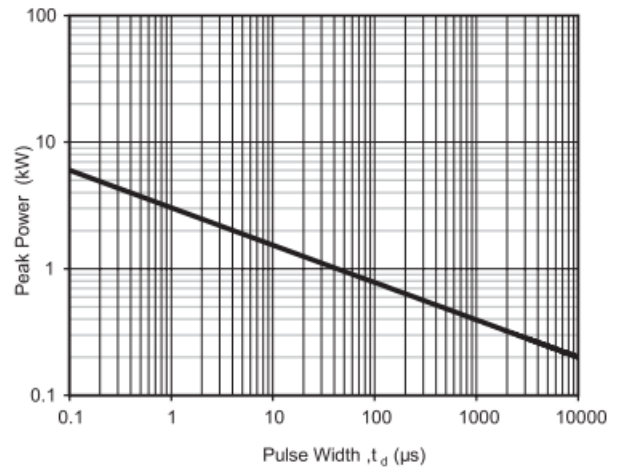

Fig. 4 - Peak Pulse Power Rating Curve

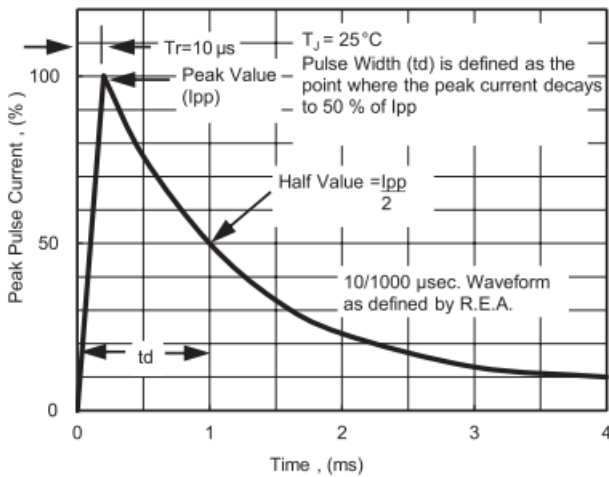

Fig. 5 - Pulse Waveform

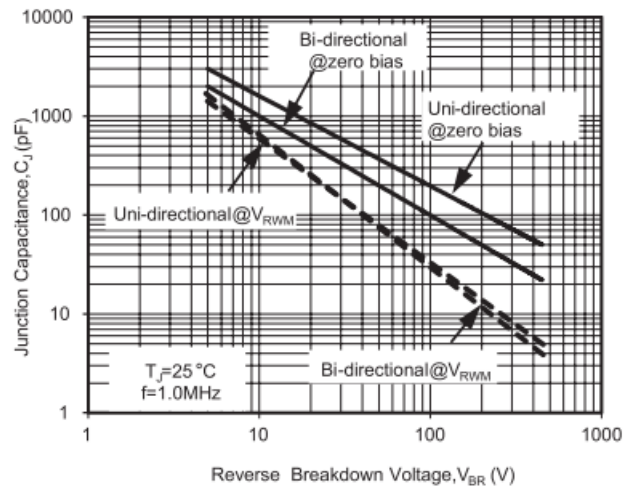

Fig. 6 - Typical Junction Capacitance

# Transient Voltage Suppression Diodes: TPSMAJ Series

## SMD Type 400 W



### IR-reflow soldering profile

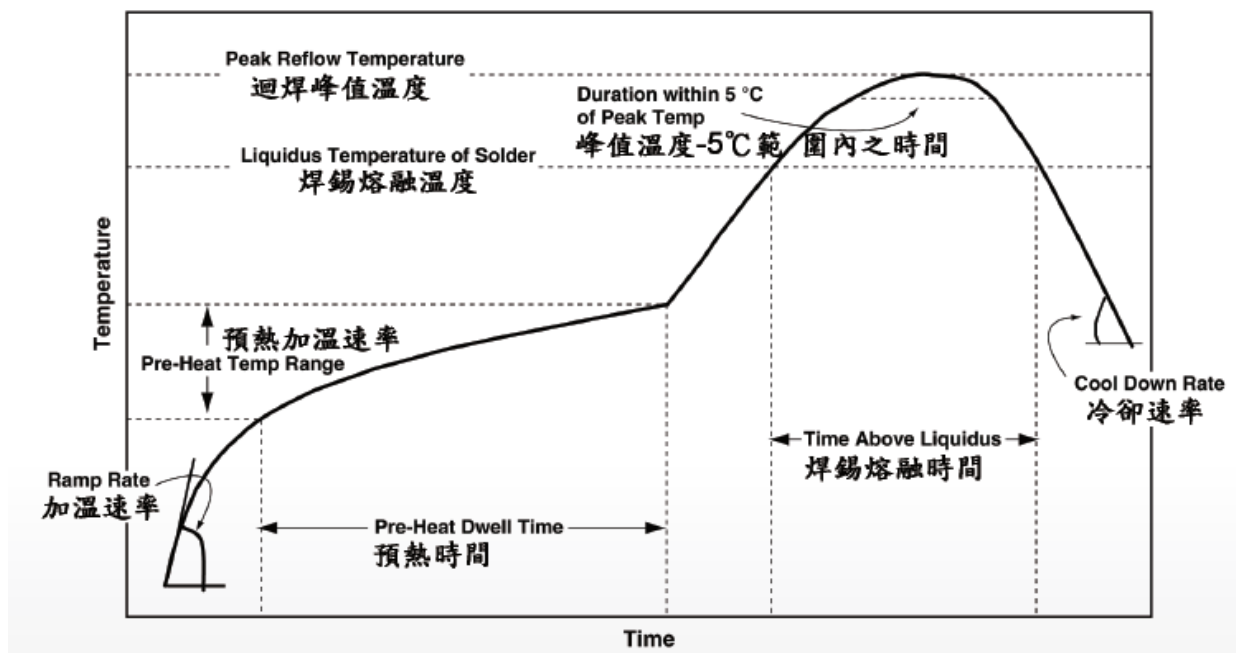

### LEAD(Pb)-FREE SOLDER(SnAgCu) REFLOW PROFILE ATTRIBUTES

PROFILE ATTRIBUTE	PROFILE ATTRIBUTE
Peak Reflow Temperature	250(+10/-5)°C
Time within 5°C of Peak Temperature	30s max
Liquidus Temperature of Solder	217°C
Cool Down Rate	6 °C/s max
Time above Liquidus	60s to 150s
Pre-heat Temperature Range	150°C to 200°C
Pre-heat Dwell Time	60s to 120s
Maximum Ramp Rate	3 °C/s max

# Transient Voltage Suppression Diodes: TPSMAJ Series

## SMD Type 400 W



### ■ Packaging

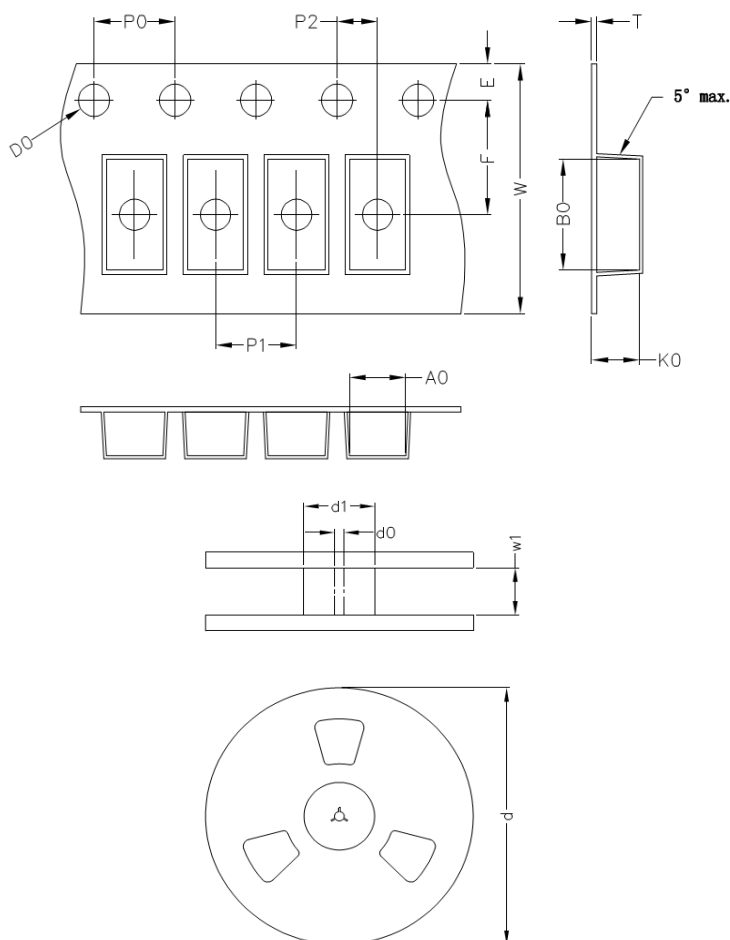

Item	Symbol	DO-214AC (SMA) Unit: mm
Carrier width	A0	2.8
Carrier length	B0	5.33
Carrier depth	K0	2.36
Sprocket hole	D0	1.55
Sprocket hole position	E	1.75
Punch hole position	F	5.5
Sprocket hole pitch	P0	4
Carrier pitch	P1	4
Embossment center	P2	2
Tape thickness	T	0.4
Tape width	W	12
Reel outside diameter	d (13")	330
Reel inner diameter	d1	75
Feed hole diameter	d0	13.5
Reel inner width	w1	14.4

Note: The tolerance of carrier tape and top cover is  $\pm 0.1\text{mm}$ , and the tolerance of reel is  $\pm 2\text{mm}$

### ■ Quantity

MPQ: 5,000pcs

Package Type	Reel Size	Reel	Inner Box
	inch	Kpcs	Kpcs
DO-214AC	13	5	10

### ■ Warehouse Storage Conditions of product

- Storage Condition:
  - Storage Temperature: 15~30°C
  - Relative Humidity:  $\leq 75\%RH$
  - Keep away from corrosive atmosphere and sunlight.
- Period of Storage: 1 year.